



MUVO

ENJOY WORKING.

muvo



WWW.RASCO.EU



CONTENT

Mobile workplace	6
Unique upgradable platform	8
Manoeuvrability	10
Smart technical solutions	12

MUVO implements

Spreader	16
Mono-segment snow plough	18
Variable snow plough	19
Snow blower	20
Front brush	21
Vacuum sweeper	22
Front washer	24
Device for cleaning special surfaces	24
Front mower	25
Crane mower	26
Waste collection container	28
Skiploader	29
Front mulcher	30
Watering set	31
Water tank	32
Tipper box	33
Aerial platform	34
Post-sales support	37
MUVO technical specifications	38

MEET MUVO

Small vehicle of great possibilities

Municipalities, cities and utility companies, as well as a number of specialised companies need a reliable, multifunctional vehicle that can be used throughout the year. RASCO's solution to this problem is MUVO, a small multifunctional vehicle that can perform various jobs by exchanging working implements. Some of MUVO's possible applications include snow clearing and salt spreading on roads, cleaning roads using a vacuum sweeper, mowing grass and vegetation, washing streets, watering flowers and municipal waste collection. Implements that provide MUVO with such a wide range of applications are designed for simple use, easy maintenance and fast replacement.

With a multifunctional design, small dimensions, strong engine, hydrostatic drive, uniquely designed chassis, small turning radius, large payload capacity and in-built smart technical solutions, MUVO can replace most specialised machines.

Numerous applications, small dimensions, power, robustness and supreme manoeuvrability options make MUVO the right choice for crowded city streets and narrow and tight spaces. High vehicle usability, a long warranty and ensured maintenance and service ensure low total ownership costs and make MUVO with accompanying implements the smart choice for any vehicle fleet.

MUVO – ONE VEHICLE FOR NUMEROUS APPLICATIONS



WINTER WORKER

Performs winter service tasks

MUVO is a reliable helper for clearing snow and ice from sidewalks, bike paths, city squares and narrow passages in winter conditions. Combination of the BILO M snow plough, VERTUS M variable plough or snow blower with the SOLID XM spreader enable efficient, simple and safe removal of snow and ice from city surfaces.

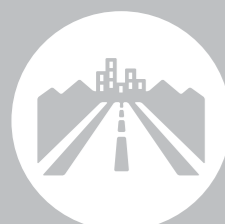

CITY CLEANER

Cleans roads, parks and squares

The SX2 sweeper in combination with a system of two or three brushes during the spring, summer and autumn months turns MUVO into a powerful city cleaner. The sweeper's capacity of almost 2m³ is adequate for removing small rocks that remain after the winter service, sand, leaves and litter from city streets. By a simple transformation of the sweeper tank into a water tank, MUVO turns from a cleaner into a washer of city areas, walking trails and underground garages.

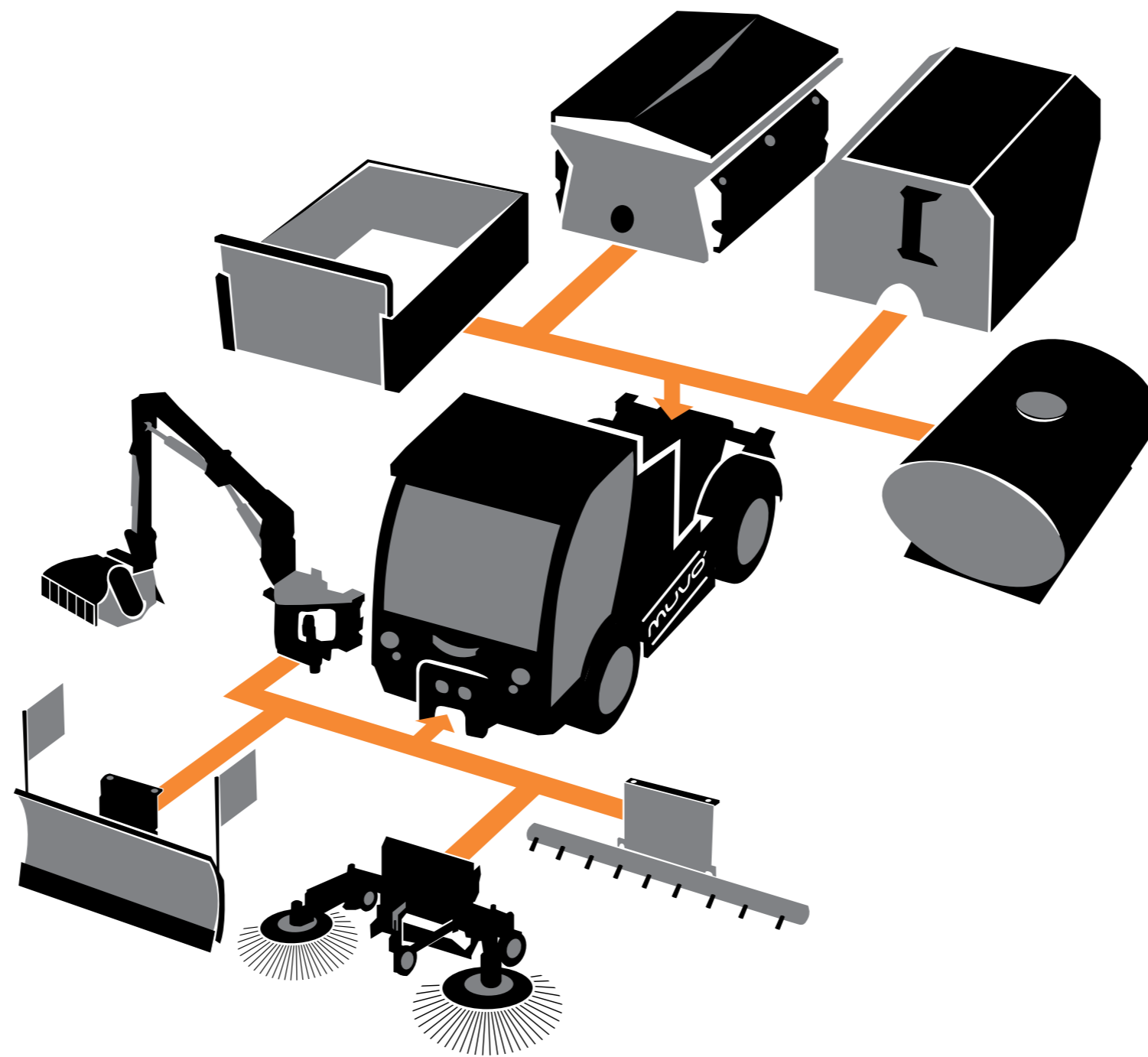

HARDWORKING GARDENER

Maintains vegetation by the side of roads, parks, orchards and vineyards

MUVO turns into a reliable gardening machine with the use of a front mower with horizontal rotary blades or a front crane mower. The SX2 sweeper's tank can be used for suction of mowed grass from the front mower, and the maintenance of hardly accessible vegetation by the side of roads is no longer a problem with a crane mower. MUVO can be equipped with a mulcher for cultivating overgrown areas, and with a watering set for maintaining flowers and vegetation on green traffic islands and lamp posts.



EXTRA WORKER

Always at hand

MUVO is ideal for waste collection, works at height, cargo transport, cleaning ditches and any other jobs that you might have to perform. Equipped with an adequate implement, MUVO is always at hand for any task you may imagine.

MOBILE WORKPLACE

Workplace with a clear view

Intended for use 24/7 for 365 days per year, MUVO is designed as a comfortable mobile workplace which provides the driver with comfort and simple control over the vehicle and implements. Seat position, large glass surfaces, air conditioning, windshield heating and sophisticated, yet easy to use, technological solutions with a centrally placed control panel enable safe and comfortable use of MUVO for multiple hours even in the hardest working conditions.



VISIBILITY

Accessible cabin entrance, panoramic heated windshield, door completely made of glass and heated rear-view mirrors offer good overview and safe control over the work of implements in front of, above and below the cabin.



ONBOARD COMPUTER

Easy viewable onboard computer with colour screen, placed centrally in the vehicle cabin, displays and controls all vehicle functions. The user can choose among four displays which provide him with all information on the operating parameters of the engine, hydrostatic drive, hydraulic system and the state of all important vehicle systems.



VENTILATION SYSTEM

The installed ventilation system ensures an adequate flow of fresh air and prevents the fogging of windows. In addition to the heating system, the standard MUVO equipment also includes an air conditioning device for maximum comfort when using the vehicle during warm and long summer days.



SEATS

The seats equipped with a mechanical or air suspensions dampen the vibrations that are transmitted from the ground and vehicle suspension to the driver and passenger. Both seats have an integrated safety belt which provides users of the vehicle with maximum safety.

UNIQUE UPGRADABLE PLATFORM

Robustness and power in a small package

Although it has small dimensions, MUVO is a powerful vehicle of great capacity that is designed for long-term operation under a full load. The choice of drive aggregates, the design of the vehicle chassis and hydraulic system enable a wide range of applications of this small multifunctional vehicle.



ENGINE UNIT

A powerful turbo diesel engine placed transversally to the vehicle chassis provides drive power to all of MUVO's systems. With the system for damping vibrations and the electronic control of the number of revolutions, driving and controlling MUVO is comfortable and easy. The engine unit complies with the EURO norms, which guarantees a high standard of environmental care by minimizing the components of exhaust gases that are harmful to the environment.



CHASSIS AND UNDERCARRIAGE

MUVO's chassis is made from high quality steel and it is designed to enable a central placement of the sweeper's suction hose. With a gross load of 2800 kg per each axle, low gravity centre and an optimal load distribution on the front and rear axle, MUVO has all the predispositions for installing a large number of different implements.



HYDRAULIC SYSTEM

Two-circuit hydraulic system with couplings on the front and rear part of the vehicle is designed to power large number of MUVO implements. Front plate relief enables precise adjustment of the pressure of the front tool on the surface, which saves fuel, eases control of the vehicle and extends the lifespan of the implement. The operating parameters of the hydraulic system are controlled electronically from the vehicle cabin. A strong and automatically controlled oil cooling system secures undisturbed vehicle operation even at the highest external temperatures.

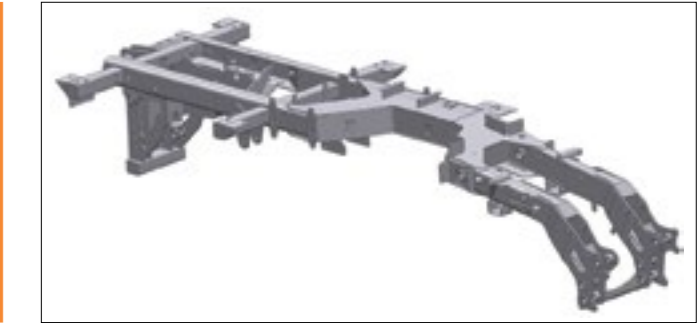

TRAILER COUPLING

Trailer coupling available in three forms (automatic, ball and VARIOBLOC) enables connecting a trailer to MUVO, thus increasing its transport capacity.

MANOEUVRABILITY

Drive and control system adjusted to a wide range of applications

MUVO's dimensions are adjusted to operation in small and narrow spaces, but use on open roads is viable as well. Uneven and tilted terrains also do not represent a problem due to the design of the drive and control system adjusted to all working conditions.



STEERING

MUVO is controlled using a steering system with cylinders on both axles. This kind of control system enables only front-wheel steering, steering with all four wheels (4WS) and diagonal steering for easier access to corners. The safety system implemented in the vehicle's central computer disables the use of steering modes that might cause the vehicle to become unstable at higher speeds.



FOUR-WHEEL DRIVE

In normal working conditions MUVO uses rear-wheel drive. Four-wheel drive (4WD) can be turned on for driving on demanding and slippery terrains and achieving maximum torque.

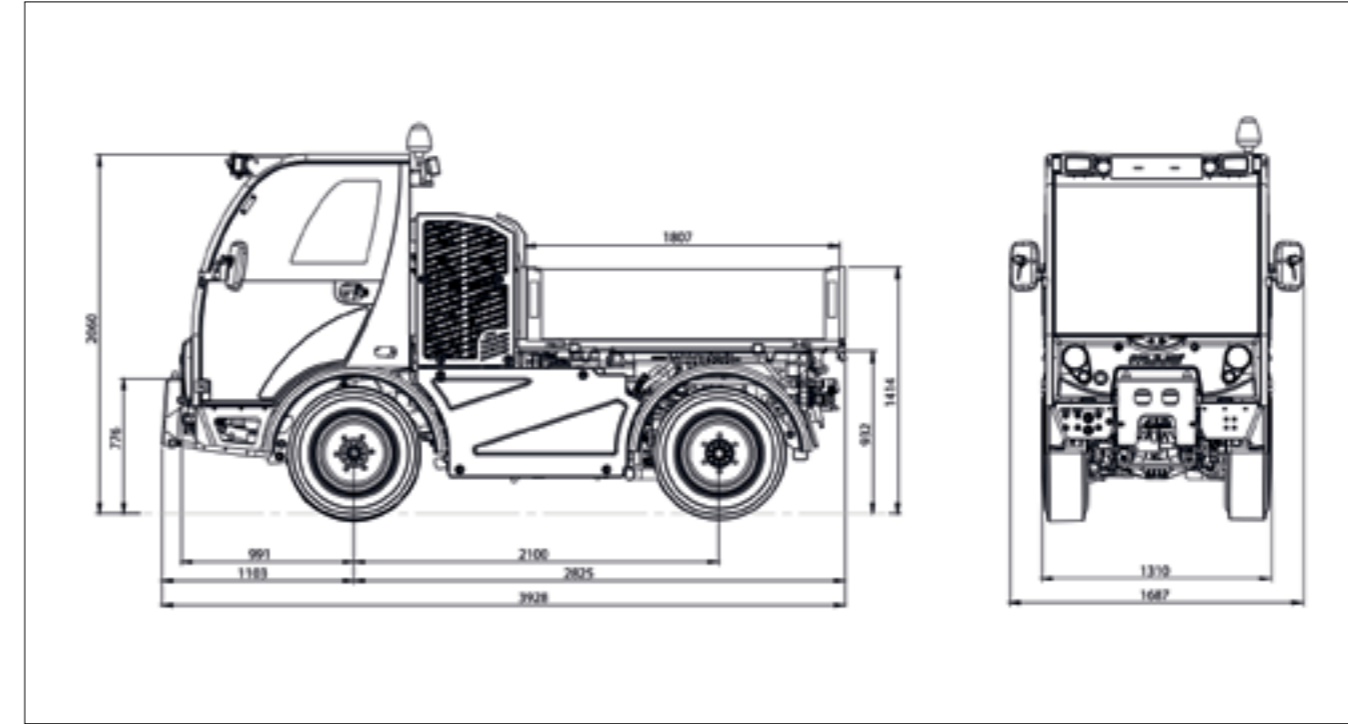

HYDROSTATIC DRIVE

The hydrostatic drive provides a quick response and enables maintaining a constant speed at different work load and precise adjustment of the speed of movement. It provides MUVO with two driving modes – “transport” and “working”, which can be alternated under load and without stopping the vehicle. The transport mode enables quick movement between two workplaces, while the working mode enables the use of devices which require extremely low driving speeds and at the same time a great power for working tools drive.

BRAKING SYSTEM

The braking system with four-wheel discs and a two-stage brake booster efficiently stops MUVO. Braking is also supported by the vehicle's hydrostatic drive, and the mechanical or electro-hydraulic parking brake is capable to keep MUVO in place even under full load.



VEHICLE DIMENSIONS

Small dimensions enable the use of MUVO in small and narrow spaces, and combined with an advanced control system they provide MUVO with a minimal turning radius and result in excellent manoeuvrability capabilities.

SMART TECHNICAL SOLUTIONS

Advantages of MUVO

RASCO experts equipped MUVO with technical solutions that enable safe work, simple maintenance and efficient use of the drive aggregate. High-quality components by verified suppliers that are dimensioned, mounted and connected using the knowledge and experience of RASCO experts make MUVO an implement carrier that is able to respond to all municipal maintenance needs in urban areas.



TRANSVERSALLY POSITIONED ENGINE

MUVO's engine is placed on the right hand side by the front axle, transversally to the chassis. In addition to accomplishing an optimal load distribution and a low gravity centre, this kind of placement ensures an easy access to key engine parts and makes regular maintenance and service interventions fast and simple.

OPTIMALLY DIMENSIONED HYDRAULIC SYSTEM

The hydraulic system is designed so as to provide the necessary power to drive most MUVO implements at an optimal engine operating point, thus saving fuel and reducing the emission of exhaust gases. This solution is especially important when using the sweeper, in which case the optimal point of the engine's fuel consumption efficiency is when the sweeper is demanding maximum suction strength.



CENTRALLY POSITIONED SUCTION PIPE

The suction hose connecting the front implements with the sweeper's tank is located centrally in relation to the vehicle chassis, thus accomplishing an optimum suction quality. A combination of a centrally located suction hose and a transversely placed engine makes MUVO a unique utility carrier.



AUTOMATIC CONTROL OVER KEY SYSTEMS

The in-built electronic system automatically regulates the work of MUVO's key system with the aim of increasing its lifespan and safety of use. The cooling system automatically maintains an optimum temperature of the engine and hydraulic oil and enables four-wheel drive also in transport driving speed while simultaneously locking the rear wheels for driving safety.



DUAL-SPEED GEAR BOX

In addition to the working and transport speed of the hydrostatic drive, MUVO also has a dual-speed gear box. The combination of a hydrostatic drive and gearbox provides MUVO with a total of four speeds for driving forward and for reverse driving. Thanks to this, a very slow speed for working with a snow blower, mulcher or mower as well as uphill movement under full load do not represent a problem for MUVO.

MUVO IMPLEMENTS

Implements as the key to MUVO's multifunctionality

MUVO's multifunctionality is based on technical predispositions of the vehicle and the number of used implements. Because the electronic and hydraulic systems have been designed in compliance with the applicable standards, MUVO can be used as a drive vehicle both for implements developed and manufactured by RASCO, as well as for implements created by third party manufacturers.

RASCO implements for MUVO include almost a quarter of a century of experience in creating equipment for summer and winter maintenance of traffic infrastructure. Each implement is designed for fast and simple mounting and demounting from the vehicle and is made from high-quality materials in a controlled production process, as well as tested in detail at the end. This is why MUVO implements, just like other RASCO products, are simple to use and maintain, efficient, safe for use and long-lasting.



SOLID XM SPREADER

The SOLID XM spreader is used for de-icing or anti-icing on city roads, squares, sidewalks, parking lots and other places which cannot be accessed by larger winter service vehicles. SOLID XM can be used for spreading salt, sand or stone granules. If equipped with a pre-wetting system, a dry agent can be mixed with chloride solutions in order to increase the spreading efficiency.

The auger conveyor system ensures a constant flow of material to the spreader's distribution system, which results in precise spreading. Blades located at the end of the auger conveyor prevent the passage of large clumps of material onto the distribution spinner and ensure a uniform dosage of spreading agents.

Control over functions, which are identical to those of the SOLID family of spreaders, is performed through the EPOS control unit installed in the vehicle cabin.

The wide selection of equipment for the spreader includes protective meshes and tarpaulins, a pre-wetting system, sensors and control systems for work automation, signalling lights and reflective marks for better visibility and legs for storage after the winter season.

Just like all SOLID spreaders, SOLID XM is designed for simple use and maintenance, it is precise and reliable during operation and safe for use. In combination with MUVO, it is the right choice for winter service in urban areas.

Volume of solid agent hopper	0,85 - 1,5 m ³
Volume of liquid agent tank	480 lit.
Spreading width	1 ÷ 6m (2 ÷ 9m)



SINGLE SEGMENT SNOW PLOUGH

Due to its compact dimensions, BILO M enables MUVO to manoeuvre easily through small and narrow spaces covered in snow. Designed as a mono-segment plough, it is ideal for removing snow at small distances.

The plough is equipped with a mechanism with triple security – swivelling scrapers enable the simple transition over obstacles, supporting elements in the form of caster wheels prevent the plough’s lodgement, while the hydraulic system becomes activated when the plough has to be raised due to encountering large obstacles. The integrated system for absorbing impacts ensures minimal stress for the vehicle and its operator, while the side bumpers prevent damage to the plough due to contact with curb endings. Safety is also enhanced by the reflective marks and flags which make the plough noticeable and clearly visible to all traffic participants.

Multipart swivelling scrapers of the plough enable good adherence to the surface, ensuring efficient clearing of snow and slush, while the axial tilt mechanism enables adjustment to any surface. In combination with MUVO, BILO M is an indispensable tool for simple manoeuvring and clearing of snow from sidewalks, parking lots and narrow streets in urban and rural areas.



Width at the scrapers	1600 - 2400 mm
Wing height	750 mm
Rotation angle	30°
Number of segments	4 / 5
Scraper types	Steel, rubber, polyurethane

VARIABLE SNOW PLOUGH

The VERTUS M plough is intended for a wide range of applications due to variable wing geometry which enables several different plough configurations. In the diagonal position, the plough removes snow to the left or right side; the position “A” is used for the first pass when removing deep snow, while the “V” position is intended for snow clearing without throwing of snow.

Intended for clearing snow in urban areas, the VERTUS M plough has numerous mechanisms that guarantee safe and efficient clearing of snow. The swivelling scraper mechanism ensures simple transition over obstacles without damage to the road surface, supporting elements prevent the plough from sinking into the ground and protect the scrapers from damage, while reflective marks make the plough visible even in the most difficult weather conditions. Bumpers on each wing protect the plough from damage when encountering obstacles such as walls or high curbs.

Variable geometry of the VERTUS M plough makes them suitable for performing several different winter service tasks, from a plough for making passages to a plough for collecting snow. The plough is primarily intended for cities with narrow streets, mostly covered with parked vehicles, where its variable geometry and adaptability to the width of the area being cleared is put to best use.



Width at the scrapers	1800 - 2400 mm
Wing height internal / external	660 / 800 (750 / 920) mm
Rotation angle	40°
Number of segments	4
Scraper types	steel, rubber

SNOW BLOWER

The snow blower is intended for removing high snow. The blower can remove the snow to the exact desired place, which is especially useful for operation in urban areas.

Powered by a hydraulic engine over a two-stage gearbox, the blower is equipped with safety systems that prevent breaks in case of encountering a foreign object.

The snow ejection chute is made from a low friction material in order to ensure a maximum snow removal distance. The direction of snow removal can be adjusted from the vehicle cabin, due to the hydraulically controlled snow deflector and exit chute that can be rotated. Thanks to its compact dimensions, a high clearing capacity and precise removal of snow, the snow blower is a good choice for places that are often covered with high snow.



Clearing width	1400 mm
Cutter diameter	650 mm
Impeller diameter	600 mm
Snow ejection	up to 20 m

FRONT BRUSH

The MKM front brush is used to clean roads, pathways, parking lots and other asphalt or concrete surfaces throughout the year. Available in three dimensions (with a brush width of 1600, 1800 or 2000 mm), it enables quick and easy snow removal in the winter season, while in the rest of the year it can be used to remove dirt, leaves, rocks and other debris. The special construction of the brush enables cleaning uneven surfaces such as pavements made of stone or concrete blocks, different gradients of asphalt, or damaged surfaces with cracks and holes.

The polypropylene brush segments allow the device to be used on sensitive surfaces without causing damage. For rougher and harder to clean surfaces, polypropylene and steel wire segments can be combined for better results.

The device is equipped with supporting wheels which reduce the pressure on the surface and prevent the brush segments from wearing too quickly. When not in use, the brush is placed on storage legs which prevent damage to the segments due to long-term contact with the surface.



SX2 VACUUM SWEEPER

SX2 is a multi-purpose implement that can be adjusted to all needs for cleaning and washing surfaces in urban areas due to various front attachments. Equipped with an SX2 vacuum sweeper, MUVO becomes competition for compact sweepers.

The standard delivery of SX2 includes a front cleaning system with two independent movable brushes with a maximum cleaning width of up to 2.4 m. For increased cleaning efficiency, the system can be upgraded with a third brush which increases the cleaning width to 2.6 m and enables the clearing of surfaces which are not at the same level as the sweeper's wheels (sidewalks, stairs, public transport stations). In front of the front brushes, SX2 has nozzles for spraying water. Spraying water, which comes from the tank at the sweeper's rear end, facilitates the removal of dirt without raising dust. The water that is sucked into the sweeper's container is recycled and used again to lubricate the suction hose.



The sweeper is equipped with a manual suction hose for cleaning garbage disposal cans, sewer holes and areas that MUVO cannot reach with its front brushes.



The construction of the sweeper's container with a wide rear door opening enables unloading of waste into municipal containers.



Cleaning quality of SX2 vacuum sweeper was confirmed with EUcertified PM10 certificate.





FRONT WASHER

Front washing devices transform MUVO equipped with a SX2 container into a washer of public spaces, squares and streets. In this case, the whole SX2 container becomes a fresh water tank.

The washer is equipped with a separate water pump, rail with stainless steel nozzles for washing and a front curtain for protection from splashing. It is available in two designs: with or without a telescopically deployable rail with nozzles.



SPECIAL SURFACE CLEANING DEVICE

SX2 can be equipped with a washing, polishing and drying deck for cleaning smooth stone surfaces and floors of underground garages and industrial halls. The device consists of three hydraulically driven independent brushes and water spraying system with a unit for injecting an ecologically acceptable detergent. The SX2 container is used as a clean water tank and a container for cleaned dirt.

FRONT MOWER

The front mower with four horizontal blades is intended for the maintenance of parks and other green surfaces in urban areas. The mowing height is adjustable in the range from 10 to 100 mm, and the in-built system of axial tilt guarantees quality and uniform mowing.

The mowed grass is collected in the SX2 container through a central suction hose, or ejected through the mower's side aperture.



CRANE MOWER

The front crane mower with a reach of up to 4 metres is intended for the maintenance of vegetation by the side of roads. The mower's crane arms are made from high quality steel and they can be installed with multiple types of working attachments, which increases the number of the mower's possible applications.

Just like all RASCO crane mowers, it is equipped with an advanced control and safety mechanisms. Safety hydraulic elements prevent breaks and damage to the mower if the working attachment encounters an obstacle, and the control system and system of working attachment relief guarantee safe and uniform work and good following of the terrain configuration. With the possibility of working both on the left and right hand side, the maintenance of vegetation by the side of roads is no longer a problem.

Excellent overview during work due to mounting on the front side of the vehicle, as well as safe and simple control with the possibility of choosing between different working attachments, makes the crane mower a reliable and flexible device for maintaining vegetation.



MOWING HEAD

The mowing head is used for mowing smaller vegetation. A rotor with a spiral distribution of blades is used to mow and shred vegetation precisely and with minimal energy consumption. The shape of the housing and location of protective elements are adjusted for work in populated areas.



WASTE COLLECTION CONTAINER

For the removal of waste from narrow streets of old city centres, MUVO can be equipped with a utility container with a capacity of 2.7 m³. The container has a thrust board for compacting waste and an automated system for emptying cans of 120 or 240 litres. The emptying system is controlled via a hydraulic distributor with handles, and when not used, can be folded into transport position.



SKIP LOADER

Using the skip loader, MUVO can transport small waste containers that are often used in marketplaces, cemeteries and parks. The device has fixed arms for lifting containers with a floor width of 1,100 mm and enables emptying containers with a hydraulically controlled hook. There are two independent stabilizers at the rear side of the device in order to ensure safe work. It is powered through the vehicle's hydraulic system using levers on the hydraulic distributor.



FRONT MULCHER

MUVO can be equipped with a front mulcher for clearing overgrown grassy areas and underbrushes. The device works fast and efficient thanks to its robust construction and MUVO's working characteristics, which enable a high speed of rotor revolutions.

The device is constructed for efficient following of terrain contours, which ensures a uniform quality of cutting. Hammer blades made of hard tempered steel, placed on the rotor in a spiral distribution, cut and shred vegetation precisely while using minimal amounts of energy. The housing of the device is made from high quality steel and shaped for uniform spreading of shredded material.



WATERING SET

The combination of a water tank and front arms with a watering head is a practical solution for watering hedges and saplings as well as ornamental plants on green traffic islands and in flower beds.

The watering arm with a length of 4m is controlled hydraulically from the vehicle cabin, so the watering is performed without stopping and exiting the vehicle. Plants can also be watered both from the left and the right hand side of the vehicle. The device can be combined with any water tank meant for mounting onto MUVO.



WATER TANK WITH A LOW PRESSURE PUMP

A 1800L plastic water tank makes for the other part of the watering set. The device is equipped with a low pressure pump and manual watering hose on a reel with an automatic winding mechanism.

WATER TANK

The 2000L plastic water tank with a steel subframe can be used with any MUVO implement requiring a source of water. The tank is equipped with dividers which prevent the movement of water when the vehicle is in motion.



TIPPER BODY

MUVO can be equipped with a three-side tipper body with aluminium sides and a steel front wall. The tipper unloading system is powered by the vehicle operating hydraulics, and the direction of loading / unloading is set by inserting pins in the appropriate rotating bolts. In case of emergency, the box can be lifted with an additional manual hydraulic pump. On each side of the tipper body there are anchor points for securing the cargo using belts, ropes or chains. When not used, the body can be demounted and stored using four legs with lifts.



AERIAL PLATFORM

The aerial platform is a useful tool used for works on lighting poles, electric poles, the fronts of buildings and for the maintenance of treetops.

The platform has a reach of up to 10m and can rotate 350°. The in-built safety sensors for stabilization and the maximum lever angle prevent the platform from tilting dangerously during operation.

The device is controlled from the ground through an electronic unit or by using the controls located in the basket. A manual hydraulic pump is also included for emergency cases.



Reach	10 m
Horizontal movement	4,20 m
Basket dimensions (LxWxH)	70x70x110 cm
Basket load capacity	120 kg
Rotation angle	350°





POST-SALES SUPPORT

Along with a high-quality product, every RASCO solution also offers a fast and reliable post-sales support

Post-sales support is provided by educated staff and based on an IT system that guarantees consistent processing of customer claims. All employees in the Customer support department have passed through all manufacturing stages during their career in RASCO and are very well acquainted with the functionality of RASCO machines and equipment. The post-sales team is always ready to respond to all claims and inquiries of RASCO equipment users. A special group of RASCO service experts trains the service staff of RASCO partners across Europe, in order to secure the same level of service in all represented markets.

The educated consulting team with many years of experience is available for any inquiries related to devices, the service team resolves device malfunctions, while spare part warehouses guarantee a minimised time from the occurrence of malfunctions to the return of full device functionality.

Constant focus on customer and partner support for the duration of product lifespan is the key to RASCO's success. This is why resolving malfunctions are followed by a detailed investigation of causes in order to take corrective measures to avoid any future occurrence of such malfunctions. Information gathered from customers is used to improve products and the manufacturing process.

MUVO TECHNICAL SPECIFICATIONS

DIESEL ENGINE		
STAGE III B	EURO 6	
<ul style="list-style-type: none"> • VM R754 ST.3B turbo diesel engine, with active regeneration particulate filter without urea addition • 72 kW / 98 PS at 2,600 min⁻¹, 340 Nm at 1,400 min⁻¹ • Electronic regulation of diesel engine revolutions using a pedal or push button ensures precise tool operation as well as reduced noise and fuel consumption • Gear drive train ensures reliable and durable power to hydraulic pumps and attached equipment 	<ul style="list-style-type: none"> • 80 kW / 109 PS at 2,600 min⁻¹, 420 Nm at 1,110 min⁻¹ • equipped with an SCR catalyst (“Selective Catalytic Reduction”) in addition to a DPF filter • reduces fuel consumption and noise emission, due to a new generation of control unit and fuel injection system (“common rail”) • subsequent processing of exhaust gases by urea fluid (“Adblue”) injection 	

DIFFERENTIAL AXLES DRIVE AND CONTROL SYSTEM

- Both axles are made of cast steel, providing high load capacity
- Front axle is a drive-and-steer axle with electronic front-wheel drive coupling activation (**4x4**)
- The rear axle is a drive-and-steer (optional) with a 2-speed gear box for standard driving speeds or very low speeds for equipment usage (e.g. sweeper)
- Electronically controlled blocking of the rear axle

- Hydrostatic wheel steering is electronically autonomous, with central computer monitoring vehicle safety without the driver’s influence) and enables the following:
 - Front wheels only turning (2WS) in transport or working mode as required (turning radius of 6.00m) while the aligned rear steering cylinder is automatically blocked to ensure safety while driving
 - All-round turning (4WS) of the wheels in working mode (turning radius of 3.65m)
 - Parallel turning of the wheels in working mode (instead of turning, the vehicle moves translationally in the driving direction)

HYDROSTATIC DRIVE

- Time-proven and field-tested “automotive” hydrostatic drive provides continuous speed regulation
- Manually controlled system using a joystick in the cabin, depending on the diesel engine speed
- 2-speed hydrostatic drive enables the alternation between the working (0-20 km/h) and transport speeds (0-50 km/h) under load without stopping, as well as backward driving (0-20 km/h)
- The “inching” function enables vehicle speed control using a joystick, while maintaining constant engine revolutions needed for attachments operation

ELECTRICAL SYSTEM

- Electric cables, waterproof connector, relays, fuses and wire harnesses manufactured in accordance with the automotive technology quality standards
- Light system installed in accordance with the requirements of the European quality standards for automotive technology
- Sound warning sign when driving backwards
- Battery voltage: **12 V, 110 Ah**

SUSPENSION AND UNDERCARRIAGE

- Parabolic leaf springs with additional rubber dampeners
- Hydraulic shock absorbers and torsion bars on both axles
- Chassis frame made of high-quality, high-strength steel prevents chassis twisting and torsion, enabling MUVO to easily and safely climb curbs and ridges
- Diagonal engine position along the front axle results in a low centre of gravity and in optimal distribution of tool attachments loads

OPERATING HYDRAULICS

• The operating hydraulics system consists of 2 independent hydraulic circuits that enable the operation with all demanding tools (up to 3 attachment tools operating simultaneously with the vehicle: on the front, at the back or on the chassis or inside the tipper box):

- **First hydraulic circuit** (0-15 lpm, 180 bar), enables alternating control of 6 double-acting hydraulic attachments for operating the cylinders using a joystick from the cabin:
 - 4 double-acting sections with a floating position (the crane arm of the mower, the cleaner brushes, etc.)
- **Second hydraulic circuit** (0-115 lpm, 180 bar) electronically controlled by potentiometer from the cabin via proportional load sensing valve block, enables dividing into 2 independenthdraulic circuits by means of:
 - separately regulates the flow of 0-65 lpm for front mounted tools
 - separately regulates the flow of 0-65 lpm for rear mounted tools
- one independent double-acting section of the front plate with a floating position, relief, floor pressure and a lifting capacity of 750 kg
- one independent double-acting attachment for tipper box lifting and other purposes

• An independent hydraulic circuit of the fan drive for cooling the diesel engine fluid and the hydraulic oil, electronically controlled by the computer via a temperature sensor depending on the achieved states, enables precise and timely achievement of operational temperature, both in extreme winter and extreme summer conditions

- Hydraulic oil tank volume: **47 l**

CABIN

- Compact cabin with clear lines, modern design, with anti-vibration elements, ergonomically formed with a clear front and side view, enabling safe driving in traffic and monitoring of working attachments
- High-quality protection of the fundamental anti-corrosion cabin coating made using cataphoresis
- Tinted glass enables visibility without light reflection ensuring operator comfort, while the heated windshield and outer side-mirrors provide constant visibility even in extreme winter conditions
- Side glass window panels open with by sliding forward movement
- Ergonomic seats with arm support and air suspension (optional), provide a safe and comfortable position for the driver and the passenger
- High safety three-point belt integrated in the seats offers full protection in case of an accident
- Steering column is of adjustable height and angle, equipped with multi-functional handles (speed alteration, direction indicators, lights, windshield washing)
- Central computer with a multi-functional reprogramming colour screen displays all states and warnings (vehicle speed, diesel engine revolutions, fuel amount, cooling fluid and hydraulic oil temperature, selected wheels turning mode, total travelled kilometres, daily distance etc.)
- LED status indicators display the basic states of the diesel engine and the vehicle (engine heating, battery voltage, fuel water presence, proper functioning of the engine computer, engine, oil pressure, driving light, proper functioning of the brake system, activated parking brake, proper functioning of vehicle and trailer direction indicators)

BRAKES

- Dual-circuit system with a hydraulic braking force booster
- Braking disk on both axles
- Mechanical rear axle disc parking brake

TYRES

- All season tyres type **245/75 R 16 C M+S** with a **8Jx16H2** rim as standard
- **215/75 R 15 C** with a **6Jx15H2** rim for city roads, underground garages
- **315/55 R 16 C MPT 81** with a **11x16** rim for grass, macadam, roads, etc.

MASS AND LOAD

- Vehicle mass with the tipper box: **2.800 kg**
- Vehicle mass without the tipper box: **2.600 kg**
- Overall allowed mass: **5.500 kg**
- Load of each axle: **2.800 kg**

FUEL TANK

- Fuel tank capacity: **67 l**

RASCO reserves the right to change the characteristics and specifications of products listed in this catalogue without notice. All information is provided for informational purposes only and cannot be used for other purposes.

